



Mercury Desking

C&R Interiors

C&R Ergonomics

Our ergonomic direction is employed to fulfill the two goals of health and productivity. It is relevant in the design of such things as safe furniture and easy-to-use interfaces to machines and equipment. Proper ergonomic design is necessary to prevent repetitive strain injuries, which can develop over time and can lead to long-term disability

Ergonomics is commonly thought of as the way companies customize procedures, work areas and break rooms to maximize productivity while minimizing worker fatigue and discomfort. We know that keeping your personnel energized and comfortable is important for lowering stress and maintaining job satisfaction.

Designed with ergonomics in mind, our system furniture solutions will provide you with the highest levels of comfort, utility and durability. The height (750mm), depth (600-750mm), width, and angle of R50 Radius at table edges of the workstations all address that along with back and arm supports.

C&R Systems ergonomically designed office furnishings are certified for premium grade from the Singapore Environment Council and PSB for our storage cabinets, modular storage cabinets, mobile storage cabinets and system panels.

You can be certain that the office furniture you receive from C&R Systems is of the highest quality, and has been custom designed to function comfortably in some of the most rigorous ergonomic conditions.

C&R Interiors Pte Ltd

Export Sales:
export@cnrinteriors.com.sg

Local Sales:
admins@cnrinteriors.com.sg

www.cnrinteriors.com.sg

Head Quarter

57/59 Defu Lane 9
Singapore 539295
tel +65 6488 0577
fax +65 6488 0588

Showroom

79 Anson Road #01-02
Singapore 079906
tel +65 6372 0428
fax +65 6224 4288



At C&R, we value all clients' input. It is an utmost priority that you, our valued client, actively collaborate with us through open communication, honesty, trust, co-operation and teamwork as we journey together to fulfill your desired workspace vision. We want our clients to have a sense of ownership over this process of discovery – from taking what you have in mind of your desired workspace to the actualization of the product itself.

We want to develop a close working relationship with you as we get to understand your workspace needs and assist you to develop a customised working blueprint to fulfill your objective and desired outcome. As we work together to create your desired workspace, let's not forget to be kind to the environment and practice corporate social responsibility through our socially beneficial and economically viable management of resources. At C&R, we believe in creating and working in an office environment that benefits and cares for our next generation.

Meeting

The small meeting table of Mercury sets the scene for brainstorming and encourages communication in a small group.



Conference



Mercury Desking

Aesthetic

Clean shapes, gentle contours and slim line design of Mercury creates a sense of elegance yet functional in every aspect of work environment.

Functional

The flexibility of the system enables the mix and match of legs, beams and breakouts to form the most appropriate function in different workplace.



Specifications (All dimensions are in mm)

Table

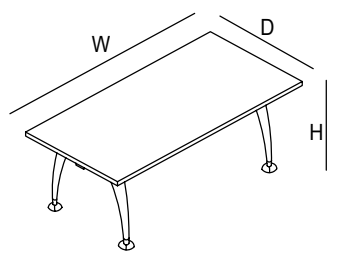

Rectangular desk
W = 1600/ 1800/ 2000/ 2200
D= 800/ 900/ 1000
H= 750

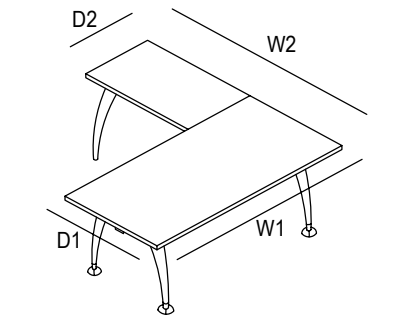

L-Shape desk
W 1= 1800/ 2000/ 2200
W2=1800/ 2000/ 2200
D1= 800/ 900/ 1000
D2= 600
H= 750

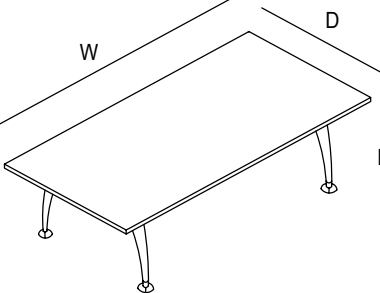

Conference Table
W= 2400
D=1200
H=750

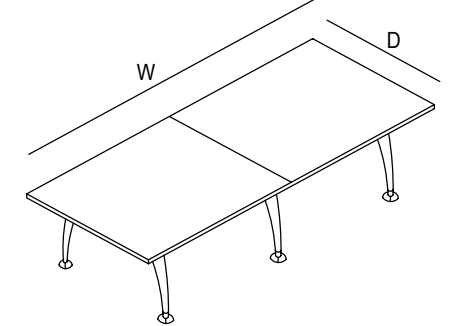

Large Conference Table
W= 2800/ 3000/ 3200/ 3600
D=1200/ 1400/ 1500
H=750

Accessories

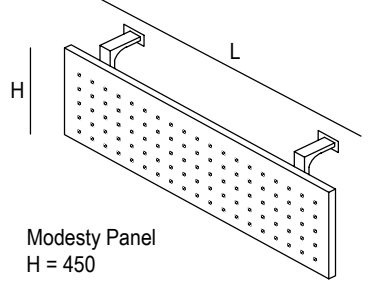

Modesty Panel
H = 450

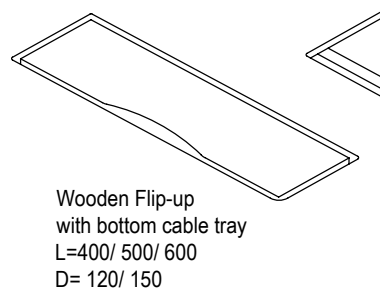

Wooden Flip-up with bottom cable tray
L=400/ 500/ 600
D= 120/ 150

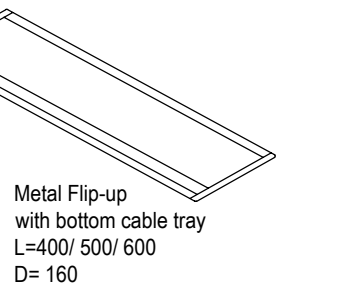

Metal Flip-up with bottom cable tray
L=400/ 500/ 600
D= 160

Mobile Pedestal

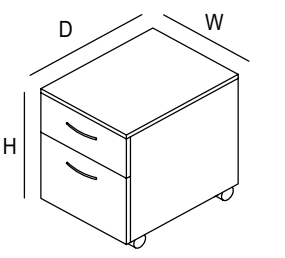

1D1F Mobile Pedestal
W= 410
D=510
H=570